

Always by your side



1. Introduction

1-1. Business Structure

Hyosung Business Structure

Hyosung's business sector includes 7 business groups (PGs), which are subdivided into 25 business areas (PUs). The individual 25 Performance Units operate as independent organizations under each different management.

Hence, the inter-related businesses among the 25 PUs are grouped into single PG, forming the final 7 PGs.

- Power & Industrial systems
- Textile
- Industrial Materials
- Chemicals
- Information & Communication
- Trading
- Construction

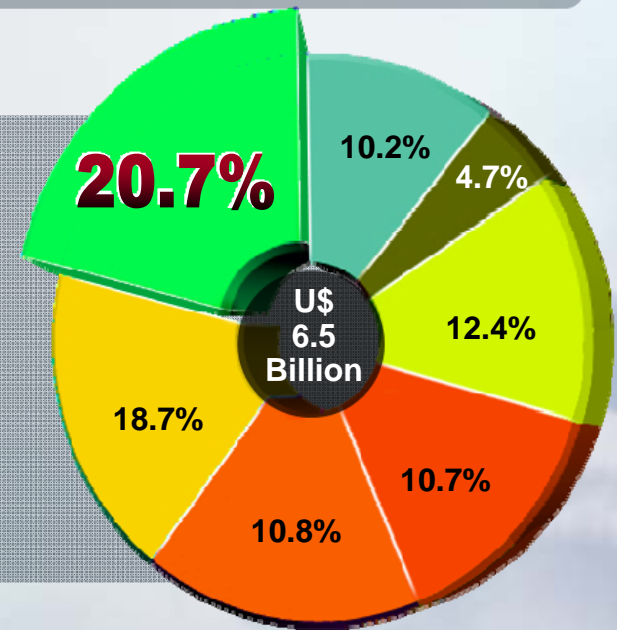

1. Introduction

1-2. Overseas Sales Networks



1. Introduction

1-3. Global Leading products

Hyosung

Power & Industrial Systems PG

- Industrial Machinery PU
- Power Systems PU
- Hyosung EBARA Co., Ltd.

Trading PG

- Steel PU
- Chemical PU
- Resource development

Construction PG

- Construction PU
- Hyosung EBARA Engineering Co., Ltd.
- Hyosung Innotech Inc.

Industrial Materials PG

- Tire & Industrial Reinforcements PU
- Technical Yan PU
- Interior PU

Information & Communication PG

- Nautilus Hyosung Inc.
- Hyosung Information Systems Co., Ltd.
- Hyosung Capital Co., Ltd.

Textile PG

- Nylon Fiber PU
- Spandex PU
- Polyester Fiber PU
- Fabric PU
- Dyeing PU

Chemicals PG

- PP/DH PU
- Packaging PU
- TPA PU
- Film PU

Korea M/S 33%

Korea M/S 65%

Korea M/S 46%

Korea M/S 28%

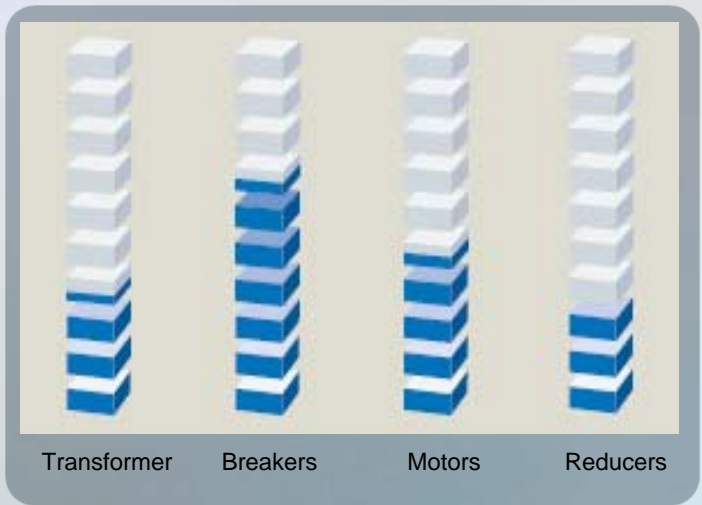

Transformer

Breakers

Motors

Reducers

<Ranked 1st in Korea>

Korea M/S 69%
World M/S 25%



Tire cords
(Ranked 1st in the World)

Korea M/S 50%

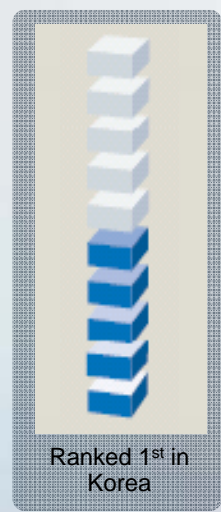

Ranked 1st in Korea

Korea M/S 53%
World M/S 12%

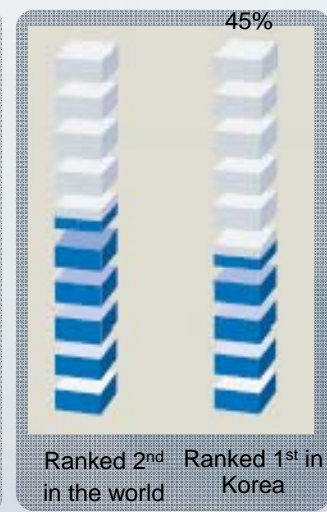

Ranked 2nd in the world

Ranked 1st in Korea

Korea M/S 55%



Ranked 1st in Korea

1. Introduction

1-4. Total Revenue

HYOSUNG CORPORATION

**Sales :U\$
6.5 Billion
(2007 year)
Headcount:
8, 000**

**Power & Industrial
Systems
Performance Group**





**Industrial
Machinery
Performance Unit**

**Power Systems
Performance Unit**

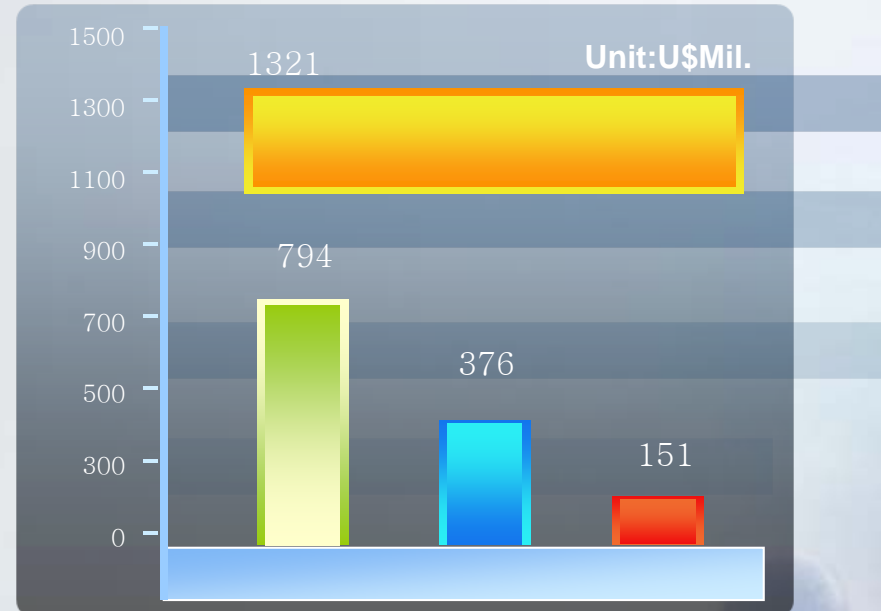
**HEC
Performance Unit**

TOTAL REVENUE



-  Power & industrial Systems PG
-  Power systems PU
-  Industrial Machinery PU
-  Hyosung Ebara Co. Ltd.

1. Introduction

1-5. Factory Overview



- Ground 80,780 m²
- Building 37,360 m²

2. Introduction of Industrial Machinery PU

2-1. Turn Over

TURNOVER : U\$ 376Million

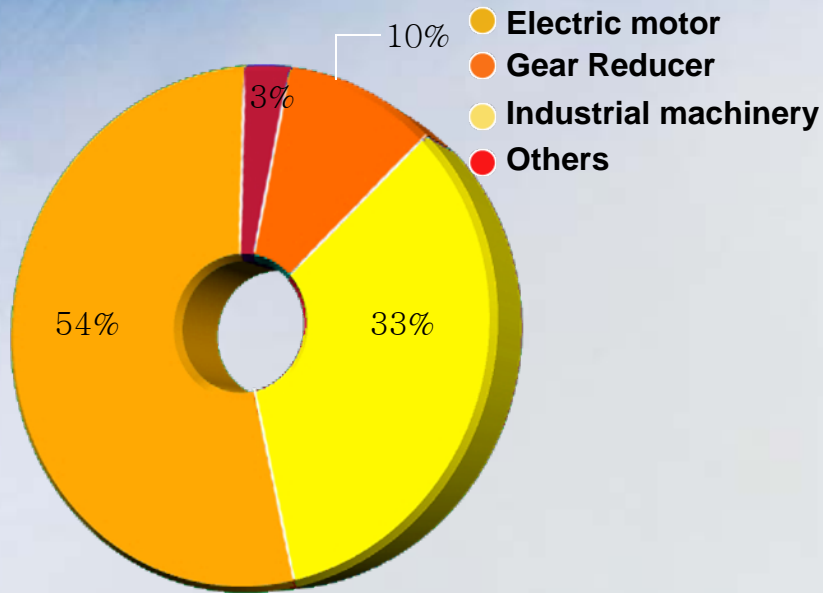

Dominant Market Leader in Korea since 1957

- More than 28% of Gear Market Share in Korea
- Leading Supplier to KEPCO, POSCO & other major private sector

Global Player in Motor and Gear Industries

- Significant Player in Japan and US Market
- Superior technology working with RENK Germany
- Specialize in Industrial & Military application

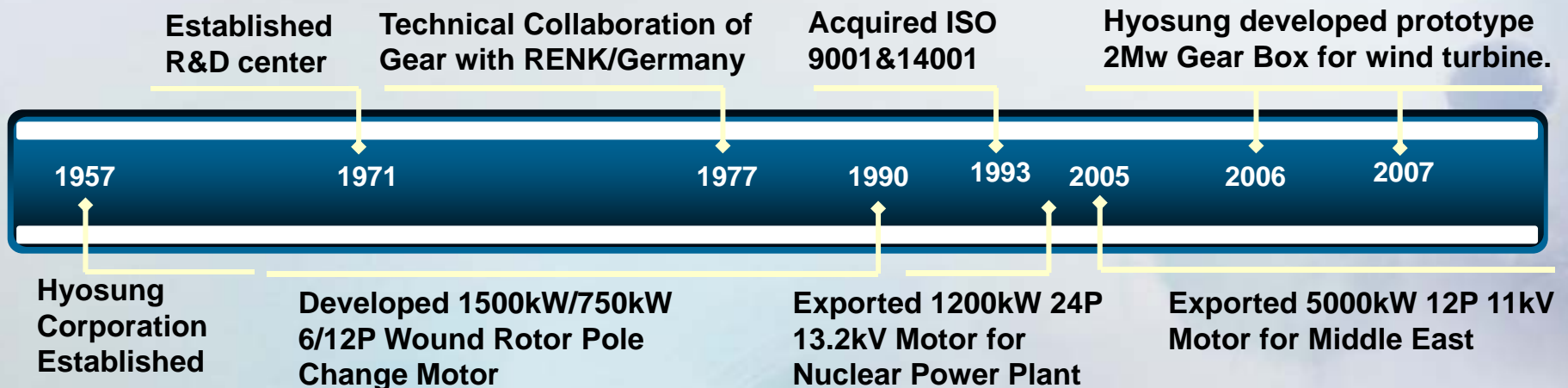

2. Introduction of Industrial Machinery PU

2-2. Organization



2. Introduction of Industrial Machinery PU

2-3. Certificate

□ ISO 9001

Quality Management System



□ ISO 14001

Environment Management System



□ OHSAS 18001

Occupational Health & Safety Assessment Series



□ NK

Explosion Protected Type for motor



□ ABS

Design Assessment for Generator, AC Synchronous



□ API

America Petroleum for Gear Reducer



□ ASME

Pressure Vessel (P,S,U,U2)

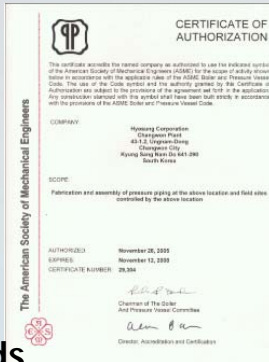

□ UL

USA CoC for L.V Motor

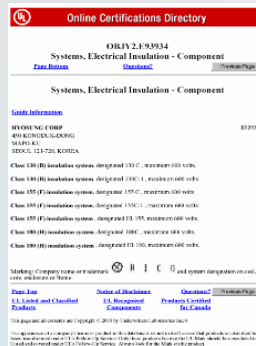

□ CSA

CSA CoC for L.V&M.V Motor



□ WYLE

Seismic Relation Safety Motor



Applicable Standards

- IEC, IEEE, ANSI, ASME, NEMA, UL, JEM, JEC, JIS, CSA, DIN, BS...



LV/MV/HV MOTORS

1. Manufacturing Scope (I)

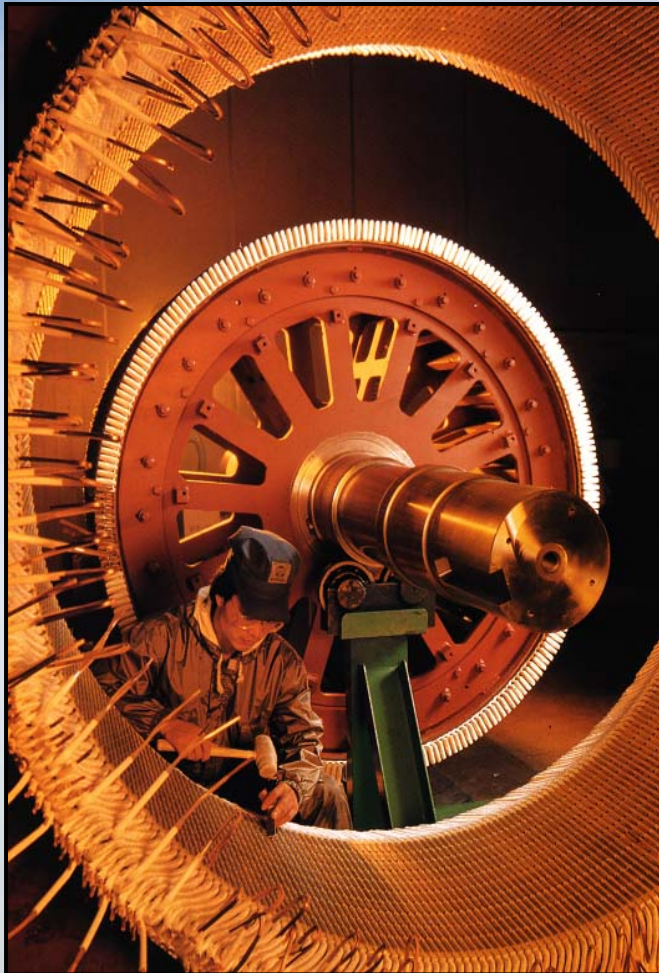

<p>Manufacturing Scope</p>	<p>A.C Induction Type</p>	<p>Range : 0.5~15,000kW 50/60Hz Voltage : 220~13,800V TEFC, TEAAC, ODP WPI, WPII</p>										
<p>Production Capacity</p>	<p>40,000 sets/month (MV/HV: 300 sets/month)</p>											
<p>Applicable Industry</p>	<table> <tr> <td>Power Plant</td> <td>Nuclear Power Plant</td> </tr> <tr> <td>Water Treatment</td> <td>Sewerage Treatment</td> </tr> <tr> <td>Desalination</td> <td>Mining</td> </tr> <tr> <td>HVAC</td> <td>Steel Mill</td> </tr> <tr> <td>Cement Mill</td> <td>Oil & Gas</td> </tr> </table>		Power Plant	Nuclear Power Plant	Water Treatment	Sewerage Treatment	Desalination	Mining	HVAC	Steel Mill	Cement Mill	Oil & Gas
Power Plant	Nuclear Power Plant											
Water Treatment	Sewerage Treatment											
Desalination	Mining											
HVAC	Steel Mill											
Cement Mill	Oil & Gas											

2. Manufacturing Scope (II)

POWER (kW)	POLE	TEFC		TEAAC		ODP		WPI		WPII	
		MIN	MAX	MIN	MAX	MIN	MAX	MIN	MAX	MIN	MAX
	2	100	500	300	3700	100	600	200	7500	200	7500
	4	100	850	300	7000	100	1250	200	10000	200	10000
	6	100	750	300	11000	100	1100	200	15000	200	15000
	8	100	600	300	11000	100	900	200	15000	200	15000
	10	100	475	300	11000	100	800	200	15000	200	15000
	12	100	350	300	11000	100	700	200	15000	200	15000
	14	100	250	300	11000	100	600	200	15000	200	15000

Note) Up to 30 Pole available.

3. Organization

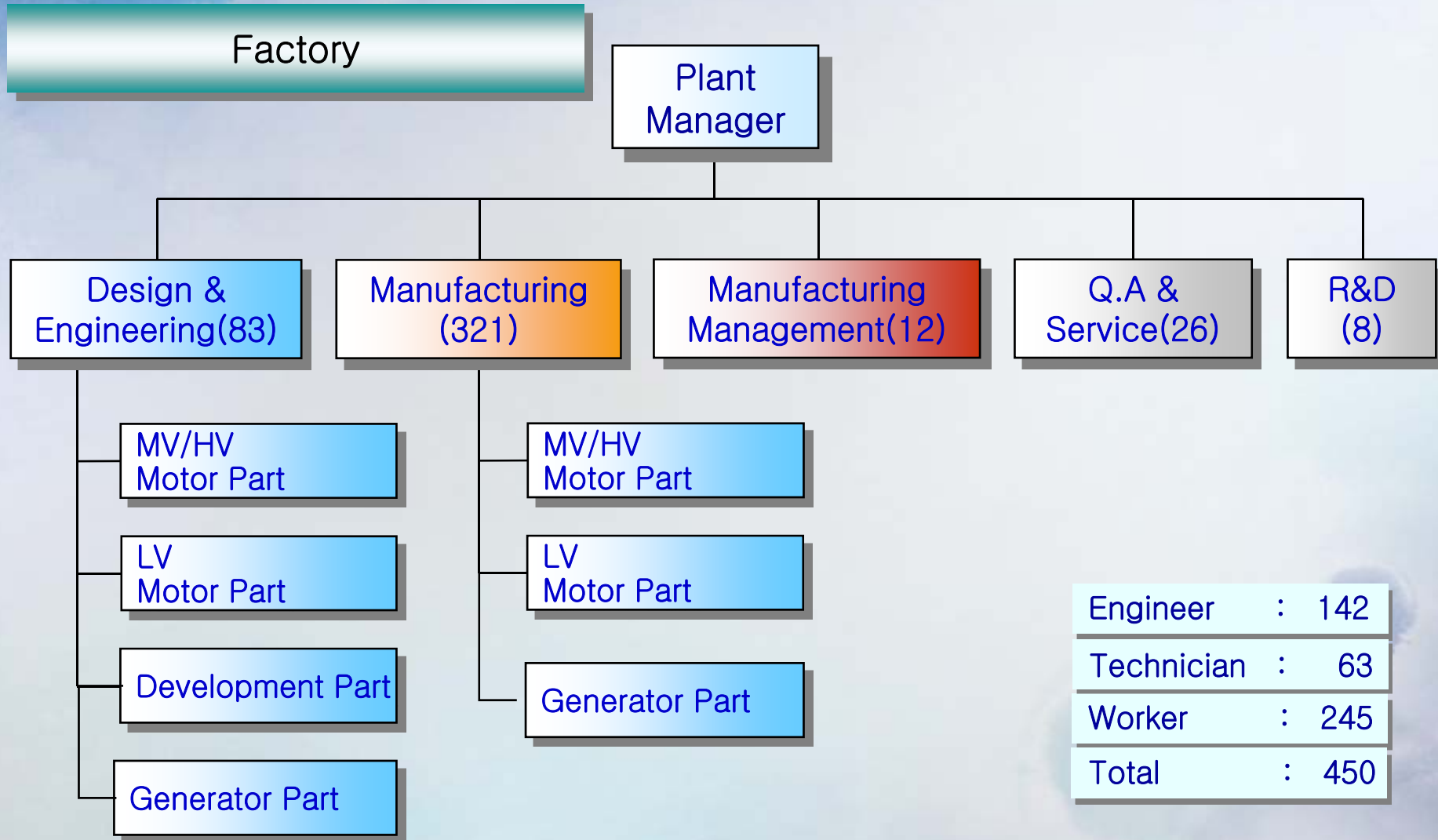

Engineer	: 142
Technician	: 63
Worker	: 245
Total	: 450

4. History

'90 '91 '92 '93 '94 '95 '96 '97 '98 '99 '00 '01 '02 '03 '04 '05 '06 '07 '08

- ▶ Developed wound rotor Pole change motor (1,500kW / 750kW, 6/12P)
 - ▶ Developed Vector Inverter Motor
 - ▶ 13.2kV motor for nuclear Power plant (1200kW, 24P, 13.2kV)
 - ▶ Fabricated the 3 millionth motor
 - ▶ Developed 8,500kW 4P motor for BFP
 - ▶ Manufactured A.C 250kW traction motor (C class)
 - ▶ Developed heavy weight torpedo propulsion motor (C.R.M)
- Developed 4400kW 10P wound rotor motor ▶
 - Manufactured 2,150kW, 22P, 13.2kV Motor ▶
 - Developed Class1E motor (ESWP, CCWP) ▶
 - Developed 9,000kW 6P wound rotor motor ▶
 - Developed 6000rpm Vector Inverter motor (420kW 2P) ▶
 - Manufactured 2800kW 18P 6600V motor ▶
 - Developed 10MVA MG-SET ▶
 - Manufactured 3900kW 12P 11kV Motor for Middle East ▶
 - Supplied 3730kW 14P 4.16kV Motor for Australia ▶
 - Supplied 5000kW 24P 13.2kV Vertical Pump Motor ▶
 - Supplied 4800kW 10P 11kV Vertical Motor for Middle East ▶

'90 '91 '92 '93 '94 '95 '96 '97 '98 '99 '00 '01 '02 '03 '04 '05 '06 '07 '08

5. Lead Time

Output(kW)	Design	Manufacturing	Packing & Shipping	Lead Time (Ex-Work)
375-750kW	2 weeks	4 weeks	2 weeks	8 weeks
750-2250kW	3 weeks	8 weeks	2 weeks	13 weeks
2250-3750kW	3 weeks	12 weeks	2 weeks	17 weeks
3750-5250kW	4 weeks	16 weeks	3 weeks	23 weeks
5250kW~	5 weeks	19 weeks	3 weeks	27 weeks

6. Major Components

STEEL PLATE : POSCO

CORE : POSCO

CARBON STEEL : SEAH BESTEEL..

ANTI-FRICTION BEARING : SKF, NSK, NTN, FAG...

SLEEVE BEARING : RENK, ZOLLERN, HYOSUNG...

TILTING PAD BEARING : TURBOLINK, RENK, MICHELL,
HYOSUNG...

CASTING : HYOSUNG...

COPPER : SAMDONG, DONYANG

INSULATION MATERIAL : HITACHI, ISOLA...

CABLE : HITACHI, SWECO

NON-REVERSE ROTATION DEVICE : STIEBER,
HYOSUNG

W.T.D : MINCO. USA, SUNGSIL, WIKA, WISE...

B.T.D : WISE, WIKA, KONICS...

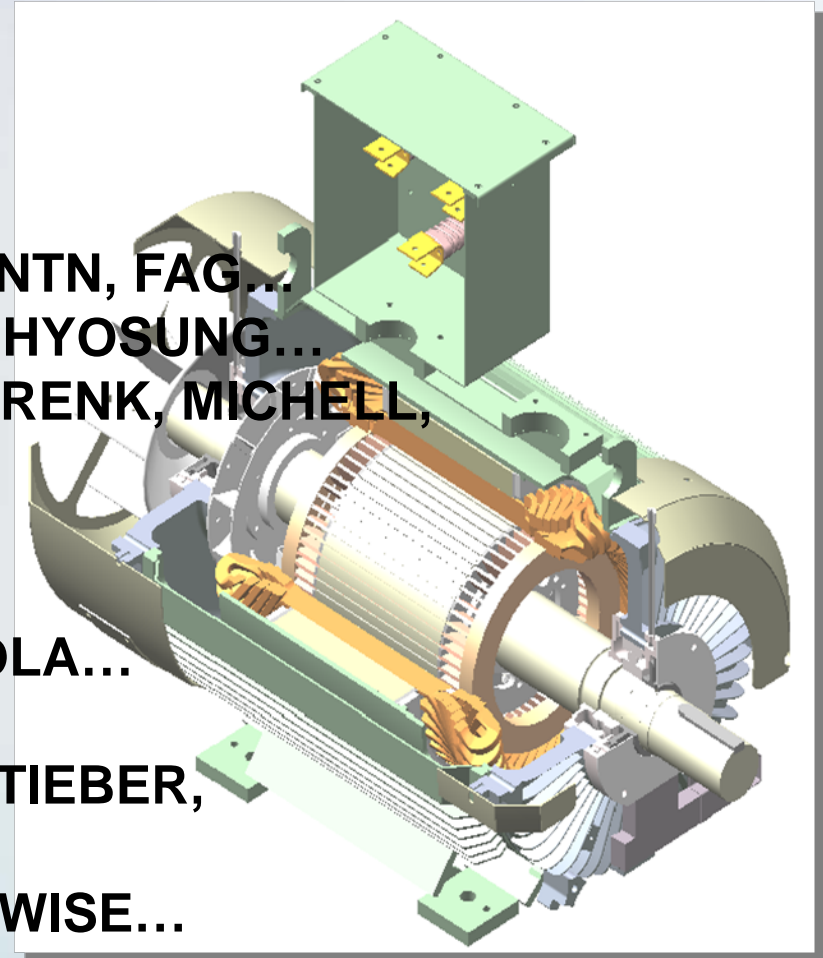

7. Status of Certificate

Country	Initials & File No.	Application	Issue Date
Canada	CSA LR61094 CSA LR61094 CSA EEV103030	General purpose Motor Class I, II Groups High Efficiency Motor	January, 1986 February, 1994 November, 1995
UL	UL E79167 UL E79167 UL E202899	Class I, II Groups Class I, II Groups (C-Face Motor) Safety for Electric Motor	April, 1983 March, 1995 July, 1999
France	ISO 9001 ISO 14000	All Products All Products	November, 1993 July, 2000
Germany	TUV CE	0.75~150kW Motor	December, 1997
U S A	Class 1E (Q Class)	LV/MV Motors	September, 2000
France	ATEX(LCIE)	LV/MV Motors Explosion Proof Type	August, 2008

- Applicable Standards ■ IEC, IEEE, ANSI, ASME, NEMA
- UL, JEM, JEC, JIS, CSA, BS

8. Status of Certificate

□ ISO 9001

Quality Management System



□ ISO 14001

Environment Management System



□ OHSAS 18001

Occupational Health & Safety Assessment Series



□ NK

Explosion Protected Type for motor



□ ABS

Design Assessment for Generator, AC Synchronous



□ API

America Petroleum for Gear Reducer



□ ASME

Pressure Vessel (P,S,U,U2)

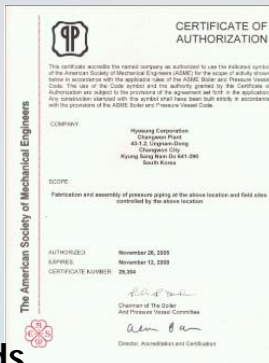

□ UL

USA CoC for L.V Motor

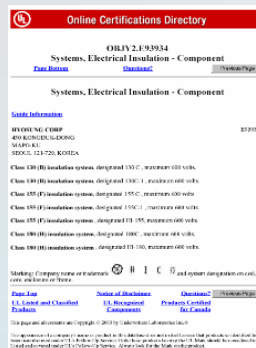

□ CSA

CSA CoC for L.V&M.V Motor



□ WYLE

Seismic Relation Safety Motor



Applicable Standards

- IEC, IEEE, ANSI, ASME, NEMA, UL, JEM, JEC, JIS, CSA, DIN, BS...